

Series	BTXLT Series 180 µl Extended Length Barrier Tip	BT200XLT Series 200 µl Extended Length Barrier Tip
Part Number	BTXLT	BT200XLT
Graduation Marks	Graduation marks are indicated at both 10 µl, 50 µl and 100 µl locations Refer to product image for visuals	
Tip Composition	Neptune pipette tips are made of virgin polypropylene	
Tip Type	S ³ - Low Retention	
Filter Material	High Density Polyethylene Filter	
Offered in Sterile Format	Yes	
Configuration	Racked	
Packaging Breakdown	96 tips/ rack 8 racks/ pack 4 packs/ case	
Autoclavable	No	
Storage Condition	Store in a clean, dry environment at room temperature 15-30 °C	

BTXLT

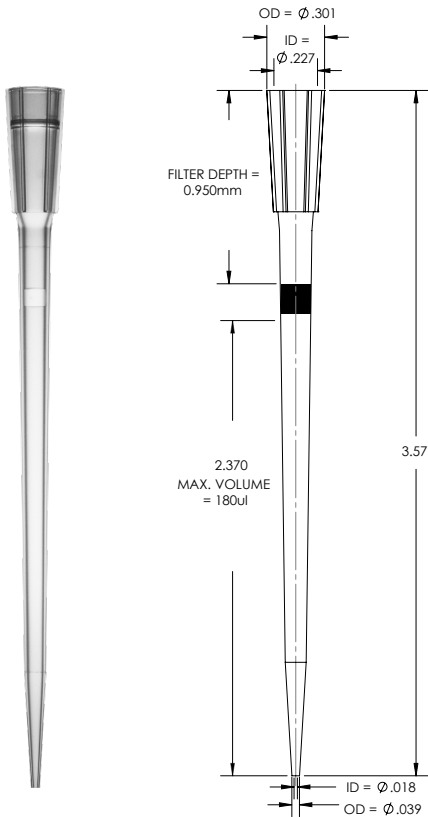

BT200XLT

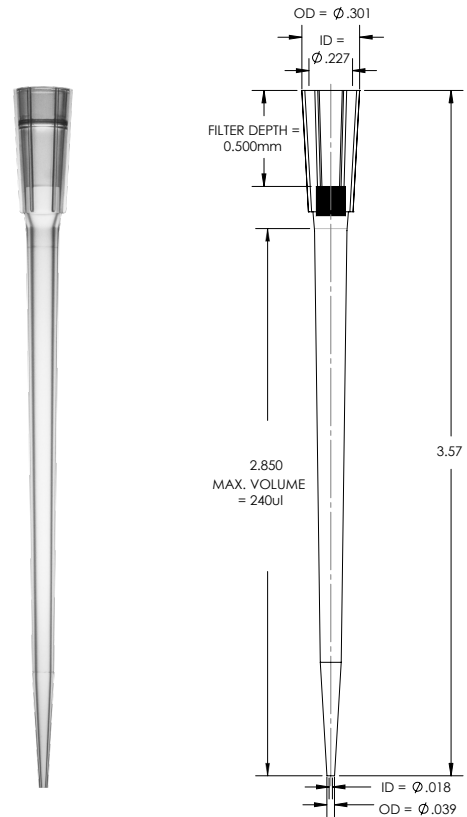

Product Specification Sheet

Quality Control:

Certificates of Compliance	Each lot undergoes stringent inspection and individual lot testing ensures Neptune products are certified RNase, DNase, DNA and Endotoxin-free. Visit www.neptunescientific.com to obtain a copy of a certificate of compliance for your Neptune product.
RNase/ DNase	Products are washed in distilled water and concentrated via centrifugation. Samples are added to previously established nucleic acid standards, incubated for one hour at 37°C, and tested on a 2% gel using electrophoresis. Products must show no degradation of standards to pass. Test sensitivity is 10 ⁻⁷ Kunitz units/μl.
Nucleic Acid	Products are washed in distilled water and concentrated via centrifugation. Then, samples are added to protocol specified PCR reactions and thermal cycled for 50 cycles. A 2% agarose gel electrophoresis is used to examine experimental samples, positive controls, and negative controls. To pass, product samples must show no DNA amplification. Test sensitivity is 10 ng.
Endotoxin/ Pyrogen	Products are tested for endotoxins by using the Limulus Amebocyte Lysate (LAL) gel assay according to FDA guidelines. Test sensitivity is 0.06 EU/ml.
Sterilization	Products are sterilized using electron beam irradiation.
Traceability	Each product contains a 5 digit lot number located on the rack, pack and case of each finished good. With Neptune's advanced manufacturing process all raw materials are able to be traced for maximum quality assurance.

Advancements in Liquid Handling

S³	Neptune's exclusive S ³ polymer was designed to increase pipetting accuracy by virtually eliminating tip retention and sample hold-up.
ESP Reload	Neptune's ESP (Environmental Sustainable Pack) was the industry's first pipette reload system designed to minimize plastic waste by 90% and provide an environmentally friendly solution.
Aerosol Barrier Tip	Specifically engineered to reduce cross contamination.

Pipettor Compatibility:

Biohit Proline™ 10 μl
 Brand Transferpette S™
 10 μl Capp™ 10 μl
 CLP Beta-Pette™ 2 μl and 10 ul
 CLP Poseidon™ 2 μl and 10 ul
 CLP Poseidon Electronic™ 20 μl
 Eppendorf Reference™ 2.5 μl
 (works with 2040 series)
 Eppendorf Reference™ 10 μl
 Eppendorf Research™ 2.5 μl
 (works with 2040 series)

Eppendorf Research™ 10 μl
 Eppendorf Research Plus™ 2.5 μl
 (works with 2040 series)
 Eppendorf Research Plus™ 10 μl
 Eppendorf Xplorer™ 10 μl
 Finnpipette™ 10 μl and 50 μl
 Finnpipette™ Electronic 10 μl
 Finnpipette F1™ 10 μl
 Gilson Pipetman™ P2 and P10
 Hamilton™ 2 μl and 10 μl
 Nichiryo Nichipet EX™ 10 μl

Nichiryo Oxford Benchmate™ 2 μl
 Nichiryo Oxford Multimate™ 10 μl
 Socorex Calibri 822™ 10 μl
 VWR Ultra High Performance™
 2 μl and 10 μl